

TEKNİK ÖZELLİKLER VE STANDART DONANIM

- Hidrolik hız ve basınç ayarı.
- NC kontrol ünitesi.
- Sağlam çelik gövde.
- Sertleştirilmiş destek direkleri.
- Doğrultma işlemleri ve farklı aparatların yerleştirilmesi için birden fazla, ısıl işlem uygulanmış destek delikleri.
- Farklı aparat ve kalıpların sabitlenebilmesi için T-kanallı bağlama tablası."
- Esnemeyi önleyen üst destek atkısı.
- Büyük ve uzun parçaların işlenmesi için ergonomik, yüksek yapısal tasarım.

ÖZEL DONANIM

- Yapılacak işe uygun kalıp tasarımı ve imalatı.
- Özel istek, revizyon ve kalıplarınız için firmamız ile iletişime geçiniz.

TECHNICAL SPECIFICATIONS AND STANDARD ACCESSORIES

- Hydraulic speed and pressure adjustment.
- NC control unit.
- Robust steel body construction.
- Hardened support columns.
- Multiple heat-treated support holes for straightening operations and mounting various tools and attachments.
- T-slot clamping table for securing different tools and dies.
- Upper support brace to prevent flexing.
- Ergonomic, high-profile design suitable for processing large and long workpieces.

OPTIONAL EQUIPMENTS

- Custom die design and manufacturing tailored to the specific job.
- For special requests, revisions, and custom die requirements, please contact our company.

MODEL		HP 120	HP 150
Max Basınç (230 bar) Maximum Pressure	ton	120	150
Düz meteryal bükme kapasitesi Flat material bending capacity	mm	30x500	40x500
Max. Piston Strok Max. Piston Stroke	mm	500	500
Takım Yüksekliği Tool Height	mm	500	500
Direk Çapı Support Diameter	mm	130	150
Çalışma Hızı Working Speed	mm/s	10	10
Dönüş Hızı Return Speed	mm/s	10	10
Motor Gücü / Voltaj Motor Power / Voltage	kW / V	5,5 / 380	7,5 / 380
Ağırlık Weight	kg	3600	4300
Ölçüler Dimensions	mm	2760x1750x1275	2960x1750x1475

HİDROLİK PRES SERİSİ KALIPLARI HYDRAULIC PRESS SERIES TOOLS

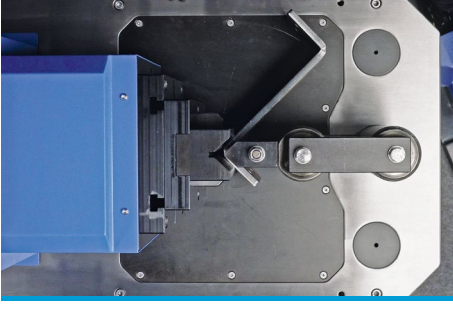

**BÜKÜM KALIBI - V KALIP
RADIUS PUNCH - V DIE**

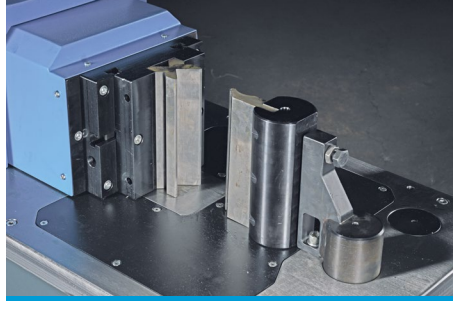

**ABKANT TUTUCU KALIBI
PRESS BRAKE TOOL + MULTI-V DIE**

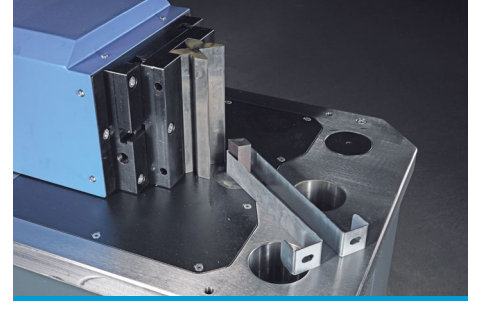

**BÜKÜM KALIBI - V KALIP
BOLT PUNCH + MULTI-V DIE**

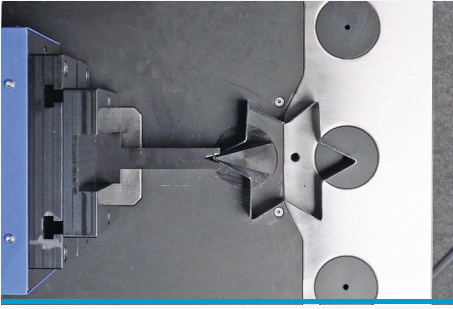

**DAR V BÜKÜM KALIBI
NARROW V DIE**

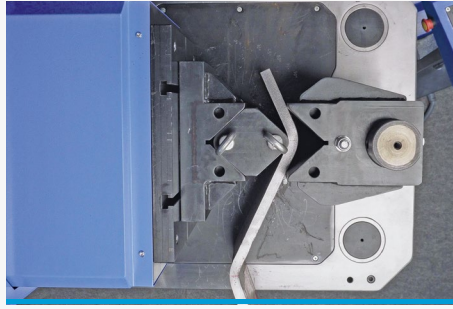

**ÇİFT YÖNLÜ V BÜKÜM KALIBI
TWO-SIDED V BENDING TOOL**

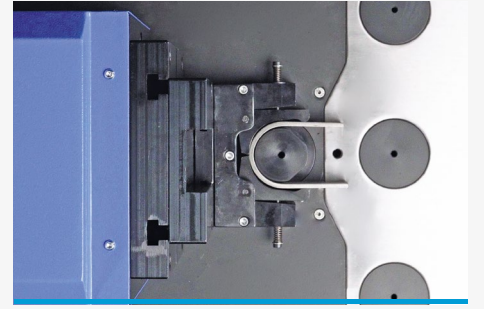

**YAYLI U BÜKÜM KALIBI
U SHAPE BENDING TOOL**



**MALAFASIZ BORU BÜKÜM APARATI
NON MANDREL PIPE BENDING TOOL**



**DOLU MİL VE KALIN BORU BÜKÜM APARATI
FLAT BAR AND THICK WALL PIPE BENDING TOOL**

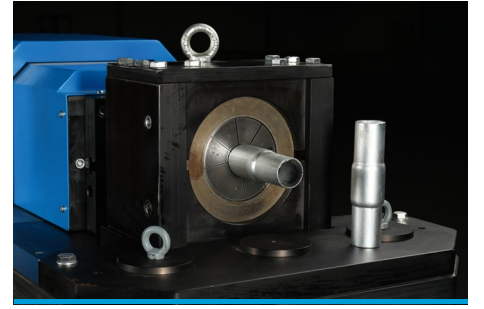

**BORU UCU DARALTMA VE GENİŞLETME KALIBI
PIPE END REDUCTION AND EXPANSION TOOL**



**PROFİL BÜKÜM KALIBI
PROFILE BENDING TOOL**

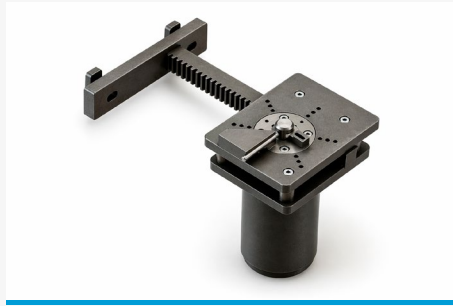

**MİL BÜKÜM KALIBI
BAR BENDING TOOL**



**BORU KELEPÇE APARATI
CLAMPING TOOL**

HİDROLİK PRES SERİSİ KALIPLARI HYDRAULIC PRESS SERIES TOOLS

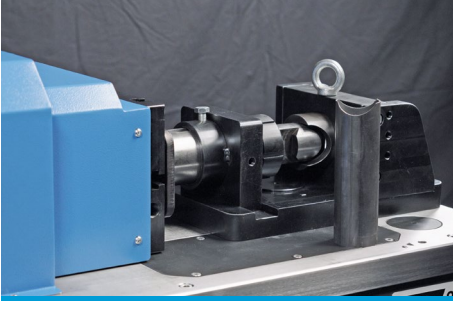

**BORU KURTAĞZI AÇMA KALIBI
PIPE NOTCHING TOOL**

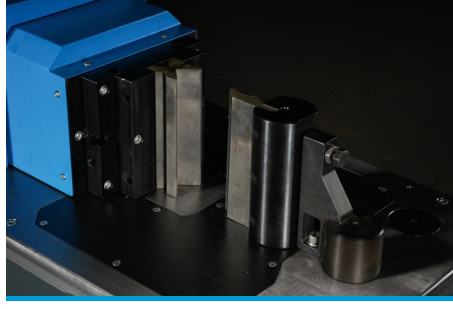

**GENİŞ RADUS BÜKÜM APARATI
WIDE RADIUS BENDING TOOL**

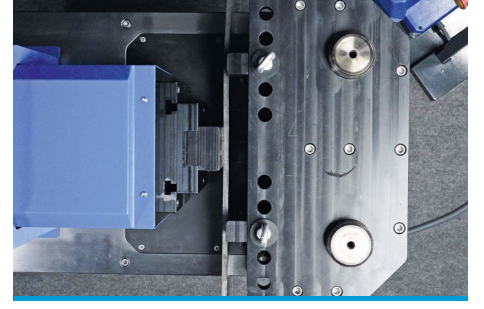

**DOĞRULTMA APARATI
STRAIGHTENING TOOL**

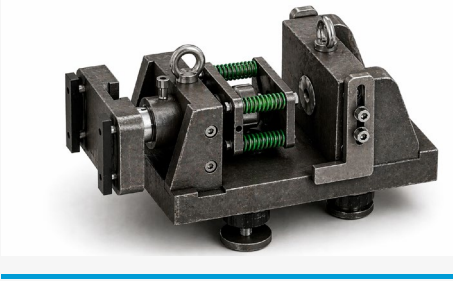

**DELİK DELME APARATI
PUNCHING TOOL**

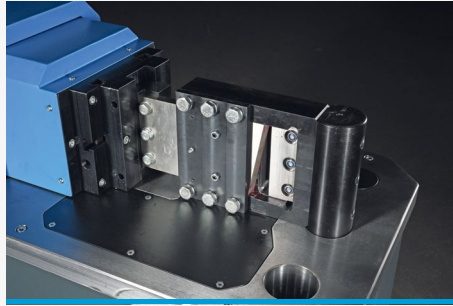

**MAKAS APARATI
SHEARING TOOL**

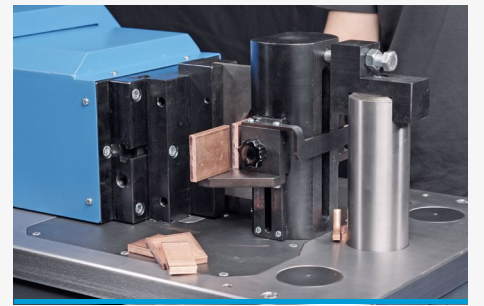

**BARA MAKAS APARATI
BUSBAR SHEARING TOOL**



**MALAFASIZ BORU BÜKÜM APARATI
NON MANDREL PIPE BENDING TOOL**



**DOLU MİL VE KALIN BORU BÜKÜM APARATI
FLAT BAR AND THICK WALL PIPE BENDING TOOL**

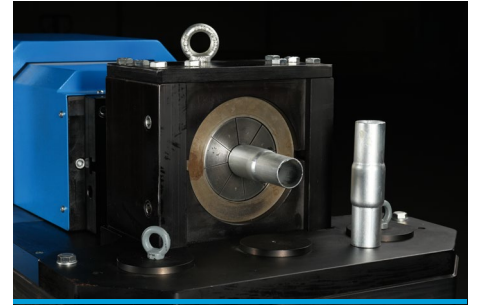

**BORU UCU DARALTMA VE GENİŞLETME KALIBI
PIPE END REDUCTION AND EXPANSION TOOL**



**BARA Z BÜKÜM APARATI
BUSBAR Z BENDING TOOL**

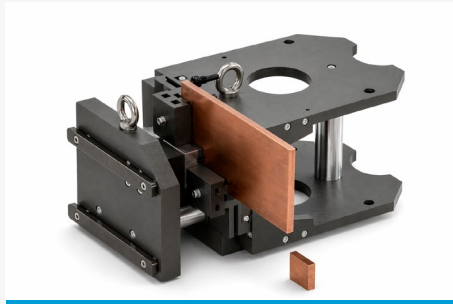

**BARA KÖŞE KESME APARATI
BUSBAR CORNER NOTCHING TOOL**



**BARA TWIST APARATI
BUSBAR TWISTING TOOL**